



VICTOR REINZ®

Sealing Products

**FOR A BETTER
INSIGHT!
PRACTICAL TIPS FOR
THE WORKSHOP**



Composite Cylinder-Head Gaskets and Damage Analysis

Tips and Practical Information No. 3

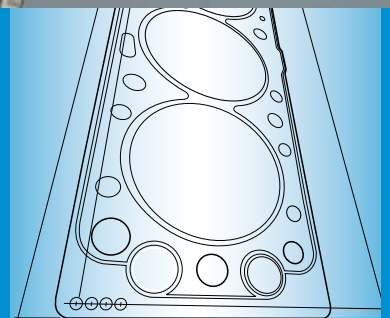



Composite Cylinder-head Gaskets – The Classical Approach to Cylinder-head Sealing

Composite Cylinder-head Gaskets

The classical composite head gasket is a compressible flat gasket. It consists of a tanged metal carrier sheet, onto which the composite material is rolled on both sides, i.e. engine block and cylinder head. Metal beads (fire rings) seal the combustion chamber and protect the sensitive composite material from overheating. The material surface is impregnated to prevent the gasket swelling when it comes in contact with liquid media such as oil, water, or antifreeze. So-called Viton elements of elastomer materials permit a partial increase of mounting surface pressure in the vicinity of oil pressure channels.

Due to the mounting surface pressure, the material is deformed slightly so that it adapts optimally to the sealing surfaces. Gaskets with low elastic recovery properties require very high bolt clamping forces for good sealing. Hereby, the minimum web width is approx. 6 mm to withstand the elevated pressures and temperatures during combustion.

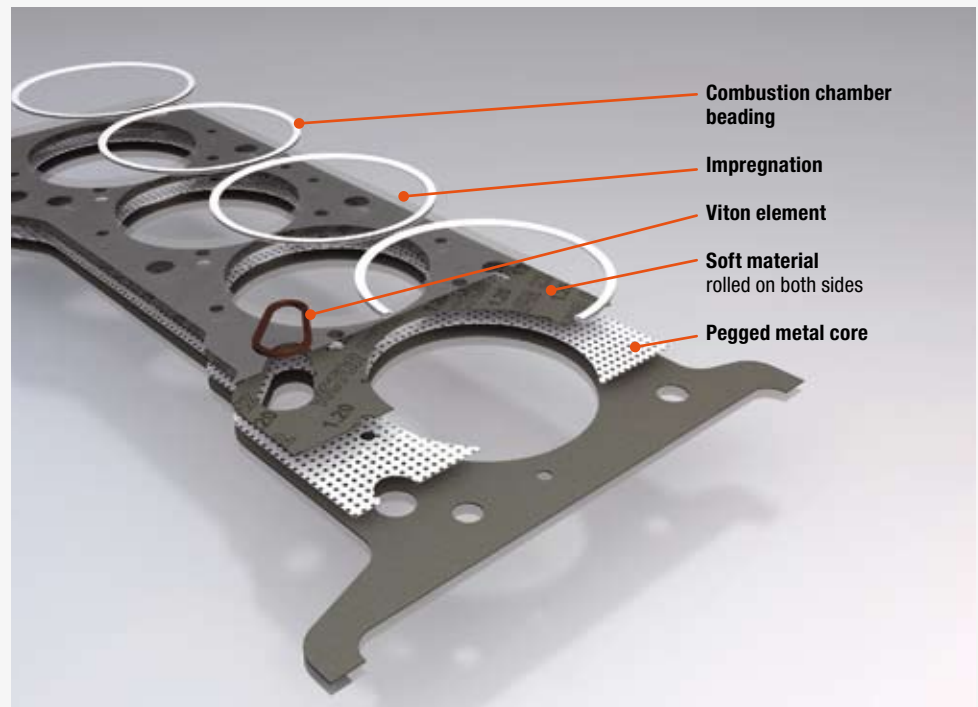

Increased Demands Due to Higher Performance

Cylinder-head gaskets must provide a gastight seal for the combustion chambers whilst simultaneously preventing leakage from the coolant and engine oil channels. In this respect, modern engines place increasingly high demands on the performance of the installed cylinder-head gasket.



Classical composite head gasket with tanged metal carrier sheet, composite material rolled onto both sides, impregnation, fire rings, and Viton element.

Overview of the demands on cylinder-head gaskets:

- Secure and lasting macro and micro sealing
- Media resistance against gas, oil, water, and anti-freeze agents
- Resistance to temperature differences and high combustion pressures
- Strength to compensate for component distortions
- Shear and tensile strength in the web area
- Transfer of bolt clamping forces
- Heat flow in the sealing gap



Damage to Composite Cylinder-head Gaskets

Different Types of Leakage

Composite head gaskets are subjected to a comprehensive testing sequence. Hereby, approval for installation is only given to top-quality and absolutely perfect head gaskets. Nonetheless, leaks can still occur during practical operation, but only in exceptional cases is this due to a faulty head gasket. There are numerous possible causes for damage to composite cylinder-head gaskets.

Gas, Oil, and Coolant Leaks

In professional terminology, leaks between cylinder head, head gasket, and engine block all fall under the general term «leakage». Hereby, a distinction is made between gas, oil, and coolant leakage, also known as «media leakage».

In total, seven different types of media leakage can occur with composite head gaskets:

- 1 Gas leakage between combustion chambers
- 2 Gas leakage from combustion chamber to coolant circuit
- 3 Gas leakage to the environment
- 4 Oil leakage to the coolant circuit
- 5 Oil leakage to the environment
- 6 Water leakage to the lubricant circuit
- 7 Water leakage to the environment

Our Tip: Analyze First, Then Repair

A faulty head gasket should be replaced as soon as possible. Gas leakages can lead to total gasket failure in a very short time, with serious consequential damage. Often, oil and coolant leakages are not noticed in their

early stages or even remain undetected. This type of damage must not be underestimated, and the head gasket should be replaced soon. Remember: A single drop of oil contaminates up to 10,000 liters of drinking water!

But don't limit yourself to a simple replacement of the head gasket. Analyze the nature of the damage first, and determine its cause. There can be many reasons for the leakage, and simply fitting a new head gasket does not automatically remove the cause.



Leakage describes a permeable point in a sealing system, through which gases or liquids can escape or enter. Leakage can cause the entire sealing system to fail.

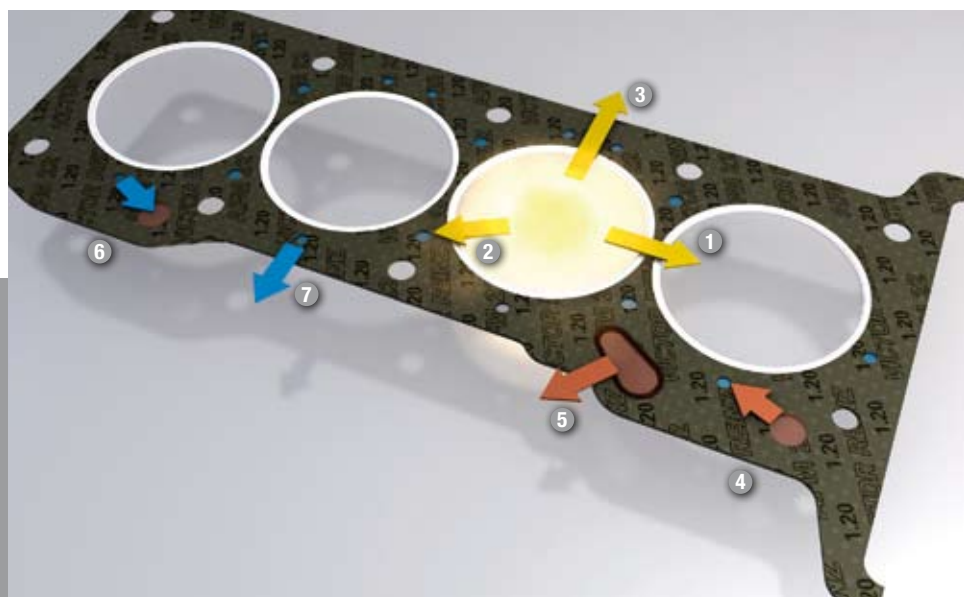

◀ Typical media leakages with composite cylinder head gaskets.

Damage, Analysis, and Causal Investigation

Blackening

The most common type of damage to composite head gaskets involves gas leakage with blackening of the fire ring, which is relatively easy to detect on a disassembled gasket. Slight blackening at this location due to thermal loading and micro leaks is normal. However, local blackening can be an indicator for real gas leakage, which will ultimately result in destruction of the fire ring due to blowby of hot combustion gases. In this case, the gasket material under the fire ring bead loses its elastic properties due to the high thermal loading. The result is leakage.

Gas leakage with blackening can be the result of insufficient sealing surface pressure or an overheated engine.



▲ Gas leakage with local blackening of the fire ring bead.

Possible causes for insufficient sealing surface pressure are faulty or reused cylinder-head bolts, incorrect torque values, damaged cylinder head and/or engine block, or non-observance of assembly instructions.

Engine overheating can be due to faults in the water pump, radiator,

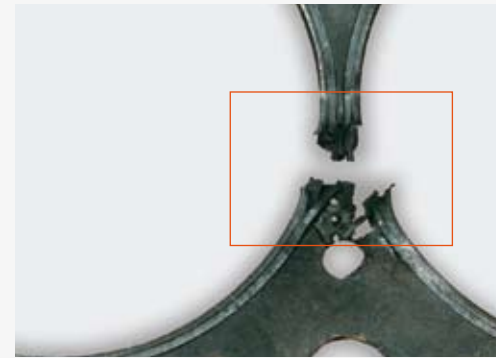

▲ Destruction in the web area due to combustion gas blowby.

thermostat or hoses, insufficient coolant, or incorrect venting of the coolant system after work on the cylinder head. Other causes for possible overheating are irregular combustion in the engine due to coke deposits, and high exhaust gas pressure in the case of catalytic converter failure.



When removing the head gasket, it is important to observe the manufacturer's instructions, in order to prevent distortions of cylinder head and/or engine block. Make sure that the component sealing surfaces are not damaged during removal of the cylinder-head gasket.

Further detailed information on the topics of cylinder head installation, head bolts, and component surfaces are given in our Practical Information No. 1 «Multi-layer steel (MLS) cylinder-head gaskets and component surfaces», and No. 2 «Cylinder-head bolts and cylinder head installation».

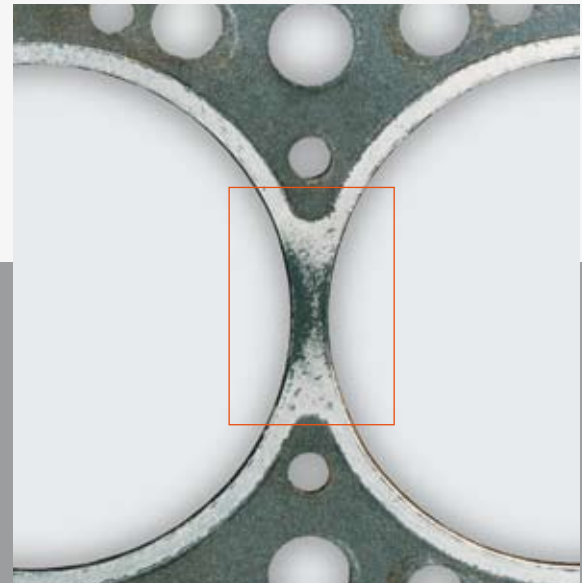

▶ Gas leakage with severe marking due to blowby of hot combustion gases.



▲ Swelling of composite cylinder-head gaskets due to overheating with steam generation.



▲ Indentation and crushing due to pre-ignition – with and without blowby.

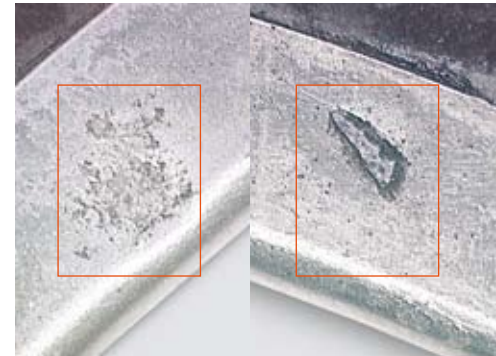

▲ Gasket damage due to dirt and foreign objects.

Swelling

Similarly, engine overheating with simultaneous steam generation will cause damage to composite head gaskets. This kind of damage is indicated by severe swelling in the areas where the composite gasket material is exposed to the coolant in the water channels. The swelling results from the destruction of the gasket material's silicone impregnating agent, which is not resistant to steam.

Indentation and Crushing

Defective composite head gaskets that exhibit indented or crushed fire ring beads have been damaged by «pinging» (pre-ignition). During this process, uncontrolled combustion causes sharp pressure increases and extremely high combustion chamber pressures. The causes for preignition are unsuitable fuels with insufficient octane rating, wrong spark plugs, incorrect ignition timing, or excessively low engine speeds over a longer period.

Oil and Coolant Leakage

As opposed to gas leakage, gasket damage due to oil or coolant leakage is very difficult to detect on a composite head gasket after disassembly. Traces of rust and antifreeze agent with white, lime-like deposits on the gasket surface can be indicators for coolant leakages. Concrete evidence for oil leakage is found very rarely.

In addition to the known causes, coolant leakage can also result from chemical additives in the coolant, or from low-quality antifreeze agents.

Dirt, Foreign Objects, and Rough Surfaces

Practice shows that reference to the importance of clean surfaces is necessary. Repeatedly, pressed-in dirt or foreign objects are the cause for damage and leakage. Therefore, the surfaces of engine block and cylinder head should be cleaned thoroughly. This applies in particular after reworking the surfaces in

TIP FROM THE EXPERTS

Instructions in case of a damaged gasket:

1. Before removing the head gasket, try to identify the location of the leak clearly.
2. Analyze the damage, and determine the cause – the gasket is not necessarily the source of the problem.
3. Remedy the cause of the damage to prevent subsequent problems.
4. Only then is it advisable to install a new head gasket.
5. Observe the manufacturer's installation instructions.

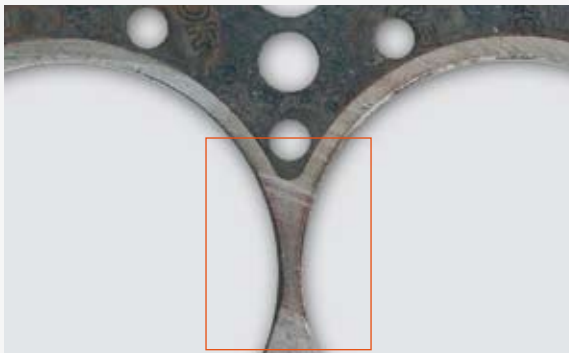

▲ *Roughness of engine block and cylinder head surfaces leads to gas blowby between the combustion chambers.*

case of component unevenness, distortion, waviness (deviations in parallelism), or roughness (scores and grooves).

Perfect seals with composite cylinder-head gaskets require a correspondingly high finish of the sealing surfaces. Excessive roughness of engine block and cylinder head surfaces leads to gas blowby between the combustion chambers and inevitable failure of the head gasket.

Additional Sealing Compounds

In the worst case, the use of additional sealing compounds will destroy the gasket through tearing or breakage of its composite material. In particular, this is true for the area around the Viton element because, as the engine warms up and cools down, the additional compound prevents the element expanding into the spaces provided. The results are tearing of the material or breakage of the Viton element.

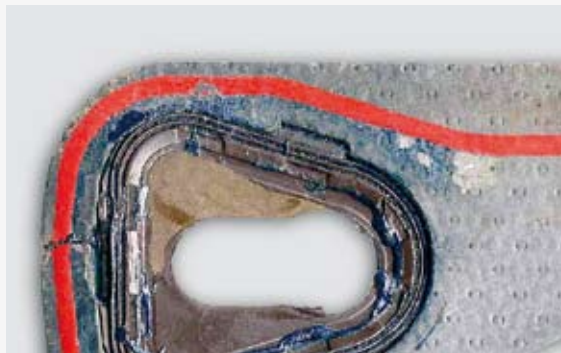

▲ *Tearing and breakage of the composite material, and damaged Viton element due to incorrect application of additional sealing compound.*

You Can Trust the Victor Reinz Specialists

Victor Reinz composite cylinder-head gaskets are your guarantee for optimal sealing results. This is not only ensured by the product's quality, but also by the enclosed installation instructions. However, in the unlikely event of gasket damage, the notes given below should be observed.

TIP FROM THE EXPERTS

When installing a composite cylinder-head gasket with Viton element, make sure that the cylinder head and the head gasket are positioned accurately. Inaccurate positioning can cause the Viton element to be overpressed or it can become damaged by sharp component edges.

Additional sealing compounds should only be applied if this is specified explicitly by the manufacturer

**Your direct contact to the
VICTOR REINZ Service Center**

T. +49 731 7046-9 99

F. +49 731 7046-4 80

E-Mail reinz.service@dana.com

SPICER®
DRIVETRAIN PRODUCTS

Axles
Propshafts

LONG®
THERMAL PRODUCTS

Transmission Oil Coolers
Engine Oil Coolers



PARISH®
STRUCTURAL PRODUCTS

Vehicle Frames
Engine Cradles

VICTOR REINZ®
SEALING PRODUCTS

Gaskets and Seals
Cylinder-Head Cover Modules
Thermal-Acoustical Protective Shielding

About Dana Holding Corporation

Dana is an integral partner for virtually every major vehicle and engine manufacturer worldwide. Dana is a leading supplier of drivetrain, structural, sealing, and thermal technologies to the global automotive, commercial-vehicle, and off-highway markets. Founded in 1904, Dana has thousands of people at operations in 26 countries.

What Can Dana Do For You?

Dana provides high-quality product solutions in four core areas of the vehicle – drivetrain, structural, sealing, and thermal systems. This lineup of technologies from one source is designed to offer flexibility to vehicle manufacturers around the world – whether in automotive centers or emerging markets – and ensures that customers get the latest state-of-the-art technologies, as well as products adjusted for specific local markets. With technology centers strategically located throughout the world, Dana engineers have the superior resources to develop, design, test, and manufacture to suit individual customer needs. This close collaboration allows Dana to create everything from advanced single components to fully integrated modular systems.

REINZ-Dichtungs-GmbH

Reinzstrasse 3-7

89233 Neu-Ulm

Germany

T. +49 731 7046-999

F. +49 731 7046-480

www.reinz.com



VICTOR REINZ®

Sealing Products